

EXV-SF Technical Data

High Lift Pallet Truck with Stand-on Platform

EXV-SF 14(i)/Li-Ion

EXV-SF 14 D/Li-Ion

EXV-SF 16(i)/Li-Ion

EXV-SF 16 D/Li-Ion

EXV-SF 20(i)

EXV-SF 20 D





Distinguishing marks		STILL	STILL	STILL	STILL	STILL	STILL	STILL	STILL	STILL	STILL
1.1	Manufacturer										
1.2	Manufacturer's type designation	EXV-SF 14/Li-Ion	EXV-SF 14i/Li-Ion	EXV-SF 14 D/Li-Ion	EXV-SF 16/Li-Ion	EXV-SF 16i/Li-Ion	EXV-SF 16 D/Li-Ion	EXV-SF 20	EXV-SF 20i	EXV-SF 20 D	
1.3	Drive	Electric	Electric	Electric	Electric	Electric	Electric	Electric	Electric	Electric	Electric
1.4	Operator type	Pedestrian/standing	Pedestrian/standing	Pedestrian/standing	Pedestrian/standing	Pedestrian/standing	Pedestrian/standing	Pedestrian/standing	Pedestrian/standing	Pedestrian/standing	Pedestrian/standing
1.5	Rated capacity/rated load	Q	kg	1400	1400 (2000) ¹	1400/1000+1000 (2000) ¹	1600	1600 (2000) ¹	1600/1000+1000 (2000) ¹	2000	2000 (2000) ¹
1.6	Load centre distance	c	mm	600	600	600	600	600	600	600	600
1.8	Load distance, centre of drive axle to fork	x	mm	724 ²	724 ² /646 ^{2,3}	924 ² /846 ^{2,3}	724 ²	724 ² /646 ^{2,3}	924 ² /846 ^{2,3}	724 ²	724 ² /646 ^{2,3}
1.9	Wheel base	y	mm	1311 ⁴	1311 ⁴ /1235 ^{3,4}	1511 ⁴ /1433 ^{3,4}	1311 ⁴	1311 ⁴ /1235 ^{3,4}	1511 ⁴ /1433 ^{3,4}	1425	1425/1347 ³
2.1	Service weight (incl. battery)		kg	1258 ⁵	1229 ⁵	1262 ⁵	1258 ⁵	1229 ⁵	1262 ⁵	1575 ⁵	1508 ⁵
2.2	Axle load, laden	drive end/load end	kg	1040/1619	952/1681	1215/1447	1059/1800	959/1874	1249/1613	1384/2191	1213/2295
2.3	Axle load, unladen	drive end/load end	kg	955/304	943/290	990/273	955/304	943/290	990/273	1141/434	1096/412
3.1	Tyres			Polyurethane	Polyurethane	Polyurethane	Polyurethane	Polyurethane	Polyurethane	Polyurethane	Polyurethane
3.2	Tyre size	drive end	mm	Ø 230 x 90	Ø 230 x 90	Ø 230 x 90	Ø 230 x 90	Ø 230 x 90	Ø 230 x 90	Ø 230 x 90	Ø 230 x 90
3.3	Tyre size	load end	mm	Ø 85 x 85 (Ø 85 x 60) ⁶	Ø 85 x 85 (Ø 85 x 60) ⁶	Ø 85 x 85 (Ø 85 x 60) ⁶	Ø 85 x 85 (Ø 85 x 60) ⁶	Ø 85 x 85 (Ø 85 x 60) ⁶	Ø 85 x 85 (Ø 85 x 60) ⁶	Ø 85 x 85 (Ø 85 x 60) ⁶	Ø 85 x 105 (Ø 85 x 80) ⁶
3.4	Support castor size		mm	Ø 150 x 50	Ø 150 x 50	Ø 150 x 50	Ø 150 x 50	Ø 150 x 50	Ø 150 x 50	2x Ø 140 x 50	2x Ø 140 x 50
3.5	Number of wheels (x = driven)	drive end/load end		1x + 1/2 (1x + 1/4) ⁶	1x + 1/2 (1x + 1/4) ⁶	1x + 1/2 (1x + 1/4) ⁶	1x + 1/2 (1x + 1/4) ⁶	1x + 1/2 (1x + 1/4) ⁶	1x + 1/2 (1x + 1/4) ⁶	1x + 1/2 (1x + 1/4) ⁶	1x + 1/2 (1x + 1/4) ⁶
3.6	Tread	drive end/load end	b ₁₀ /b ₁₁	mm	534 // 380/500	534 // 380/500	534 // 380/500	534 // 380/500	534 // 380/500	534 // 370/470	534 // 370/470
4.2	Height	mast lowered	h ₁	mm		See mast table		See mast table		See mast table	See mast table
4.3	Free lift		h ₂	mm		See mast table		See mast table		See mast table	See mast table
4.4	Lift		h ₃	mm		See mast table		See mast table		See mast table	See mast table
4.5	Height	mast extended	h ₄	mm		See mast table		See mast table		See mast table	See mast table
4.6	Initial lift		h ₅	mm	-	110	-	110	110	-	110
4.9	Height drawbar in driving position	min./max.	h ₁₄	mm	1120/1370	1120/1370	1120/1370	1120/1370	1120/1370	1120/1370	1120/1370
4.15	Fork height, lowered		h ₁₃	mm	86	86	86	86	86	86	86
4.19	Overall length		l ₁	mm	1993 ^{2,4} /2401 ^{2,4,7}	1993 ^{2,4} /2401 ^{2,4,7}	1993 ^{2,4} /2401 ^{2,4,7}	1993 ^{2,4} /2401 ^{2,4,7}	1993 ^{2,4} /2401 ^{2,4,7}	2108 ² /2516 ^{2,7}	2108 ² /2516 ^{2,7}
4.20	Length to face of forks		l ₂	mm	843 ^{2,4} /1251 ^{2,4,7}	843 ^{2,4} /1251 ^{2,4,7}	843 ^{2,4} /1251 ^{2,4,7}	843 ^{2,4} /1251 ^{2,4,7}	843 ^{2,4} /1251 ^{2,4,7}	958 ² /1366 ^{2,7}	958 ² /1366 ^{2,7}
4.21	Overall width		b ₁	mm	800	800	800	800	800	810	810
4.22	Fork dimensions		s/e/l	mm	55 ⁸ /182/1150	55 ⁸ /182/1150	55 ⁸ /182/1150	55 ⁸ /182/1150	55 ⁸ /182/1150	73 ⁸ /210/1150	73 ⁸ /210/1150
4.24	Fork carriage width		b ₃	mm	780	780	780	780	780	780	780
4.25	Distance between fork arms		b ₅	mm	560/680	560/680	560/530	560/680	560/680	580/680-570 ⁸	580/680-570 ⁸
4.32	Ground clearance, centre of wheel base		m ₂	mm	30	20/110 ³	20/130 ³	30	20/110 ³	20/130 ³	20/130 ³
4.34	Working aisle width for pallet 800 x 1200 lengthways		A _{st}	mm	2406 ⁴ /2795 ^{4,7}	2390 ^{3,4} /2777 ^{3,4,7}	2441 ^{3,4} /2828 ^{3,4,7}	2406 ⁴ /2795 ^{4,7}	2390 ^{3,4} /2777 ^{3,4,7}	2441 ^{3,4} /2828 ^{3,4,7}	2519 ⁵ /2909 ^{5,7}
4.35	Turning radius		W _a	mm	1584 ⁴ /1973 ^{4,7}	1507 ^{3,4} /1894 ^{3,4,7}	1707 ^{3,4} /2094 ^{3,4,7}	1584 ⁴ /1973 ^{4,7}	1507 ^{3,4} /1894 ^{3,4,7}	1707 ^{3,4} /2094 ^{3,4,7}	1697 ⁵ /2087 ^{5,7}
5.1	Travel speed	laden/unladen	km/h		4.0/4.0 6.0/6.0 8.0/10.0 ⁷	4.0/4.0 6.0/6.0 8.0/10.0 ⁷	4.0/4.0 6.0/6.0 7.0/10.0 ⁷	4.0/4.0 6.0/6.0 8.0/10.0 ⁷	4.0/4.0 6.0/6.0 8.0/10.0 ⁷	4.0/4.0 6.0/6.0 8.0/10.0 ⁷	4.0/4.0 6.0/6.0 8.0/10.0 ⁷
5.2	Lift speed	laden/unladen	m/s		0.16/0.30	0.16/0.30	0.16/0.30	0.15/0.30	0.15/0.30	0.15/0.30	0.15/0.30
5.3	Lowering speed	laden/unladen	m/s		0.40/0.35	0.40/0.35	0.40/0.35	0.40/0.35	0.40/0.35	0.31/0.31	0.31/0.31
5.8	Max. gradeability	laden/unladen	%		9.2 ⁹ /9.2 ⁹	10.0/22.0	10.0/22.0	9.2 ⁹ /9.2 ⁹	10.0/22.0	5.6 ⁹ /5.6 ⁹	8.0/23.0
5.10	Service brake				Electromagnetic	Electromagnetic	Electromagnetic	Electromagnetic	Electromagnetic	Electromagnetic	Electromagnetic
6.1	Drive motor, rating S2 = 60 min		kW		2.3	2.3	2.3	2.3	2.3	2.3	2.3
6.2	Lift motor, rating at S3 = 15%		kW		3.2	3.2	3.2	3.2	3.2	3.2	3.2
6.3	Battery according to DIN 43531/35/36 A, B, C, no				2PzS	2PzS	2PzS	2PzS	2PzS	3PzS	3PzS
6.4	Battery voltage/rated capacity K _s		V/Ah		24/230	24/230	24/230	24/230	24/230	24/345	24/345
6.5	Battery weight ±5% (depends on make)		kg		212	212	212	212	212	288	288
6.6	Energy consumption according to DIN EN 16796		kWh/h		0.80	0.80	0.80	0.84	0.84	0.95	0.95
8.1	Drive control				AC control	AC control	AC control	AC control	AC control	AC control	AC control
8.4	Sound level at driver's ear		dB(A)		≤66	≤66	≤66	≤66	≤66	≤66	≤66

¹ Transpallet capacity on the load arm
² With telescopic or HiLo mast (x -26 mm; l₁, l₂ +26 mm with triplex mast)
³ Wheel arms raised
⁴ +75 mm with 3PzS and +150 mm with 4PzS
⁵ Values show the telescopic mast with h₁ = 1915 mm
⁶ Truck fitted with tandem rollers
⁷ Platform lowered
⁸ Preferred while using grid box; a carriage with forks thickness s = 71 mm is also available
⁹ Geometric limit on unrounded vertex slope

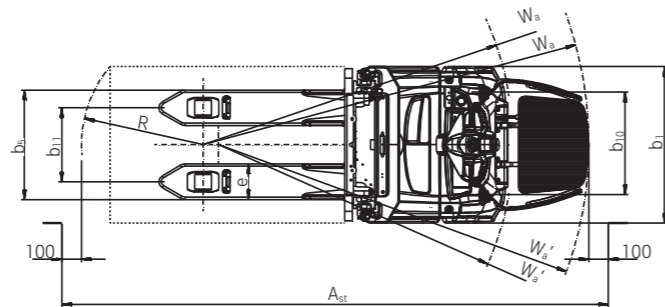

Top view

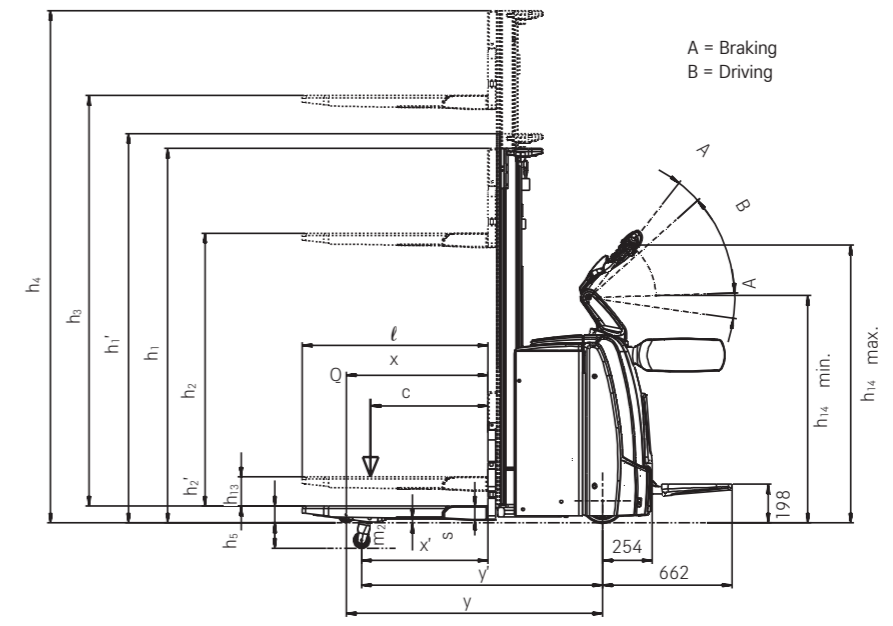

Side view

EXV-SF High Lift Pallet Truck with Stand-on Platform Mast Tables



EXV-SF 14 - EXV-SF 14i - EXV-SF 16 - EXV-SF 16i	Telescopic mast														
	Height		h_1	mm	1415 ²	1665 ²	1915	2115	2365	2565	2815				
	Mast height with free lift applied ($h_3 = 150$ mm)		h_1'	mm	1490	1740	1990	2190	2440	2640	2890				
	Free lift ¹		h_2	mm	150	150	150	150	150	150	150				
	Lift		h_3	mm	1844	2344	2844	3244	3744	4144	4644				
Height, mast extended		h_4	mm	2930	3430	3930	4330	4830	5230	5730					

EXV-SF 14 - EXV-SF 14i - EXV-SF 16 - EXV-SF 16i	HiLo mast					Triplex mast											
	Height	h_1	mm	1415 ²	1665 ²	1915	2115	2365	2565	1665 ²	1915	2065	2165	2265	2315	2365	2515
	Free lift	h_2	mm	329	579	829	1029	1279	1479	579	829	979	1079	1179	1229	1279	1429
	Lift	h_3	mm	1844	2344	2844	3244	3744	4144	3516	4266	4716	5016	5316	5466	5616	6066
	Height, mast extended	h_4	mm	2930	3430	3930	4330	4830	5230	4602	5352	5802	6102	6402	6552	6702	7152

¹ With increased mast height h_1'

² Mast not available with battery tray 2PzS and 3PzS (replacement using crane)

EXV-SF 20 - EXV-SF 20i	Telescopic mast				HiLo mast			Triplex mast				
	Height	h_1	mm	1915	2115	2365	1915	2115	2365	1665	1915	2065
	Mast height with free lift applied ($h_3 = 150$ mm)	h_1'	mm	1990	2190	2440	-	-	-	-	-	-
	Free lift	h_2	mm	-	-	-	749	949	1199	499	749	899
	Free lift ¹	h_2	mm	150	150	150	-	-	-	-	-	-
	Lift	h_3	mm	2684	3084	3584	2684	3084	3584	3276	4026	4476
Height, mast extended	h_4	mm	3850	4250	4750	3850	4250	4750	4442	5192	5642	

¹ With increased mast height h_1'



EXV-SF High Lift Pallet Truck with Stand-on Platform Detailed Photos



Everything in view, all the time: optional touch display with a range of language-independent symbols shows you all of the important functions at a glance



Safe even when cornering: automatic speed reduction around corners



Reduces back strain: air suspended stand-on platform adjustable to the individual weight of the driver



High turnover performance due to double deck transport of non-stackable goods



Ready at all times: high availability thanks to optional lateral battery change



Fast and safe: innovative battery plug lock enables fast battery replacement, without the risk of jamming



Maximum power: if the mast is not required, up to 2.0 t can be carried on the initial lift



Maximum turnover performance: 10 km/h top driving speed

EXV-SF High Lift Pallet Truck with Stand-on Platform

Power meets innovation

Optimal utilisation of storage area: high storage compaction due to very high residual load capacity

Protects the back: air-cushioned stand-on platform which can be adjusted to individual driver's weight

Everything in view, all the time: optional touch display with a range of language-independent symbols shows you all of the important functions at a glance

High handling rate due to high driving speeds of up to 10 km/h



The EXV-SF high lift pallet truck is unbelievably fast, extremely strong and highly intelligent. With an extended stand-on platform and lateral protective arms, it accelerates to a top speed of 10 km/h, and moves up to 2,000 kg of pallets in record time. Thanks to its huge residual load capacity, it can also store a great deal at a great height – depending on the mast, storage heights of well over five metres are not a problem. This smart warehouse organiser is also the only high lift pallet truck to date with an informative colour display. As well as displaying basic information, such as the battery's state of charge, numerous language-independent symbols facilitate the optimal operation of this strong high lift pallet truck. Together with its powerful

and low-maintenance motor and its precise control elements suitable for either left- or right-handed operators, it can achieve unprecedented reloading of pallets. Optional load capacity display, speed reduction around corners as standard, and optional combi-tiller provide optimum driver safety and enable the EXV-SF to turn and move easily – even in the most confined spaces. The EXV-SF high lift pallet truck, which is as strong as it is smart, means that you can always keep your flow of goods safely under control; from transporting loads within the pre-storage area to operating the shelving system – and you will be thankful for the stand-on platform over longer distances.

The 'Simply Efficient' factors: Performance attributes as a measure of economic efficiency



Simply easy

- Fatigue-free operation thanks to precise and intuitive electrical steering unit
- Precise even in the tightest of spaces with the help of sensitive proportional valve control
- High availability thanks to straightforward battery change, optionally also on the side of the vehicle
- All the information you need at a glance via a modern and easy-to-read colour display in the tiller head



Simply powerful

- Maximum storage compaction due to outstanding residual load capacity and lift height
- Power for two: even multiple-shift use can be handled without a problem thanks to high battery capacity
- High availability due to powerful lithium-ion battery with the option of interim charging



Simply safe

- Convenient and safe working: with its individual weight adjustment, the air-cushioned stand-on platform protects the driver's back and joints
- Everything in view: optional load capacity display shows the current mast height and corresponding residual load capacity
- Curve Speed Control allows fast yet safe cornering by automatically adjusting the speed to the steering angle, ensuring the optimal safe distance between forklift and driver via the optional combined tiller



Simply flexible

- The right driving programme for every situation: ECO, BOOST or Blue-Q – from maximum handling rate to highest efficiency
- Blue-Q efficiency mode allows energy savings of up to seven percent at the press of a button, with no loss of performance
- Manoeuvrable in tight spaces and narrow aisles thanks to compact dimensions and folding stand-on platform



Simply connected

- Easy and transparent web-based truck maintenance with FleetManager 4.x
- Various driver profiles can be saved, allowing straightforward truck use by multiple drivers
- Maximum transparency and needs-based fleet analysis thanks to transmission of comprehensive, use-based data

EXV-SF High Lift Pallet Truck with Stand-on Platform Equipment Variants



	EXV-SF 14	EXV-SF 14(i)/ EXV-SF 14 D	EXV-SF 16	EXV-SF 16(i)/ EXV-SF 16 D	EXV-SF 20	EXV-SF 20(i)/ EXV-SF 20 D	
General	Display and operating unit with colour display for selection of driving programme	●	●	●	●	●	
	Pneumatically cushioned folding stand-on platform	●	●	●	●	●	
	Integrated storage facilities	●	●	●	●	●	
	2-tonne load capacity with initial lift when mast is not used	—	●	—	●	—	
	Easy-grip tiller for left and right-handed operators	●	●	●	●	●	
	Tiller head with LCD display and optimised grip	●	●	●	●	●	
	Tiller head with colour touch display	○	○	○	○	○	
	Two-stage setting option for high-precision lifting and lowering	●	●	●	●	●	
	New Blue-Q energy-saving system	●	●	●	●	●	
	Various non-deflecting fork lengths	○	○/—	○	○/—	●	●/—
	Various fork lengths for pallet cage	●	●	●	●	○	○
	Accessory bar	○	○	○	○	○	○
	Electric preparation for data terminal	○	○	○	○	○	○
	Cold storage version	○	○	○	○	○	○
	High-performance rotary driving motor has very low maintenance costs	●	●	●	●	●	●
	Electrical steering unit: AC steering motor for exceptionally fatigue-free operation	●	●	●	●	●	●
	Proportional valve technology for high-precision movements	●	●	●	●	●	●
Double deck application	—	—/●	—	—/●	—	—/●	
Mast	Telescopic mast	○	○	○	○	○	
	HiLo mast	○	○	○	○	○	
	Triplex mast	○	○	○	○	○	
	Mast protective grille	●	●	●	●	●	
	Protective mast screen made from polycarbonate	○	○	○	○	○	
	Initial lift	—	●	—	●	—	
	Automatic lowering of initial lift at 1,500 mm mast height	—	○/—	—	○/—	—	
Wheels	Drive wheel tyres, polyurethane	●	●	●	●	●	
	Drive wheel tyres, polyurethane, profiled	○	○	○	○	○	
	Drive wheel tyres, solid rubber	○	○	○	○	○	
	Drive wheel tyres, solid rubber, profiled	○	○	○	○	○	
	Drive wheel tyres, polyurethane (75 Shore) for better traction	○	○	○	○	○	
	Drive wheel tyres, solid rubber, natural-coloured	○	○	○	○	○	
	Load roller tyres, polyurethane, single	○	○	○	○	○	
	Load roller tyres, polyurethane, tandem	●	●	●	●	●	
	Fully enclosed components which are impervious to dirt and dust	●	●	●	●	●	
	Stabilising wheel, single	●	●	●	●	—	
	Stabilising wheel, double	○	○	○	○	●	
Safety	FleetManager: access authorisation, shock detection, reports	○	○	○	○	○	
	Curve Speed Control: speed reduction when driving around corners	●	●	●	●	●	
	Combi tiller: adjustable tiller length for sufficient space between truck and operator	○	○	○	○	○	
	Access authorisation with STILL key	●	●	●	●	●	
	Load capacity indicator	○	○	○	○	○	
	Dynamic Load Control	○	○/—	○	○/—	○	
	PIN code access	○	○	○	○	○	
Battery	Load backrest	●	●	●	●	●	
	Battery compartment for battery up to 250 Ah for battery replacement using crane	●	●	●	●	●	
	Battery compartment for battery up to 375 Ah for battery replacement using crane	○	○	○	○	○	
	Battery compartment for battery up to 375 Ah for battery replacement using roller track and changing frame	○	○	○	○	○	
	STILL Li-Ion Battery for 205 Ah	○	○	○	○	—	
	STILL Li-Ion Battery for 410 Ah	○	○	○	○	—	
Battery compartment for battery up to 500 Ah for battery replacement using roller track and changing frame	○	○	○	○	—		
Built-in charger for battery replacement using crane	○	○	○	○	○		

● Standard ○ Option — Not available



STILL GmbH
Berzeliusstr. 10
22113 Hamburg
Germany

Tel.: +49 40 73 39 20 00

Fax: +49 40 73 39 20 01

info@still.de

For further information please visit

www.still.eu

STILL is certified in the following areas: Quality management, occupational safety, environmental protection and energy management.



first in intralogistics