

## SIMPLE YET EFFECTIVE... THIS ELECTRIC HAND PALLET TRUCK IS AN ALL-ROUNDER

Our PBPL electric pedestrian pallet trucks make moving products efficient and convenient. Unlike conventional hand pallet trucks, they feature a 48-volt Lithium-Ion power source: making them the perfect choice for short and mid distance runs. The PBPL is a user-friendly, multi-use solution for nearly any application.



PBPL12WPTP  
PBPL12IPTP  
PBPL12MPTP  
PBPL12HPTP  
PBPL12KPTP  
PBPL12JPTP  
PBPL15WPTP  
PBPL15IPTP  
PBPL15MPTP  
PBPL15HPTP  
PBPL15KPTP  
PBPL15JPTP  
PBPL15MPSP

**SPEC SHEET**

## Electric Hand Pallet Trucks

1.2 – 1.5 tonnes



With its compact design, low service weight and small turning radius, the PBPL series is ideal for use in confined spaces, including: retail stores, trailers, containers and small warehouses.

The PBPL series of 1.2 and 1.5 tonne electric pedestrian pallet trucks feature electrical driving and lifting functions, as well as a manual lowering. The exchangeable, maintenance-free, high-capacity 48V Lithium-Ion battery provides six hours of productive use. The truck is supplied with an external charging dock - allowing you to charge an extra battery in just 3.5 hours, while the truck is still in use.

#### FRAME AND BODY

- **High quality, stable construction** gives a stable and durable platform.
- **Compact, lightweight, high-performing body design** provides exceptional maneuverability in tight areas.
- **Integrated rocker arm** is casted in one piece from solid steel to ensure maximum strength and reliability. (1.5 tonne model)

#### DRIVE

- **Maintenance free brushless (AC) wheel hub motor** with no wearable components like carbon brushes or contactors to replace over time offer long-lasting operation and low maintenance.
- **Patented low noise gearless hub motor design** allows tight integration into wheel hubs, thus eliminating the need for gears.

## Mitsubishi PBPL12-15 Series

### Electric Hand Pallet Trucks

1.2 – 1.5 tonnes

#### FORKS

- **Tapered fork tips and tandem PU rollers with fork tip rollers** for easy pallet entry and exit.
- **Reinforced chassis and forks with tapered ends** offers easy pallet entry. (1.5 tonne model)

#### BRAKES

- **Regenerative Brake System with electromagnetic (parking) disk brake**, improves the braking performance and working life of the electromagnetic brake.
- **Parking brake** automatically stops on gradients and ramps.
- **Kinetic energy from the regenerative brake system** charges the battery.
- **Double brake discs** are included as standard for enhanced braking performance. (1.5 tonne model)

#### ELECTRICAL AND CONTROL SYSTEMS

- **48V/20Ah high capacity Lithium-Ion battery** lasts longer and is more powerful.
- **Li-Ion battery with no leaking hazardous battery gases and acids** does not require watering and provides maintenance-free operation.
- **External charger** makes it possible to charge the battery onboard.
- **External charging dock** allows charging an extra battery while using the truck with only 3.5 hours charging time.
- **Battery interchangeability** means that batteries can be used across all PBPL models - regardless of capacity.

#### OPERATOR ENVIRONMENT AND CONTROLS

- **Ergonomic spring-loaded steering handle** with comfort grip for reduced operator fatigue.
- **Long tiller with large ergonomic handgrip and integrated battery status indicator** provide a comfortable hold and strain-free operation.
- **Side castors** improve stability.

#### OTHER FEATURES

- **Easy maintenance with no expensive handheld required**, only a laptop, software and a cable.
- **Polyurethane wheels and rollers** for smooth and quiet running and additional grip.
- **Choice of 1.2 or 1.5 tonne models** ensures the PBPL Series suits a wide range of applications.

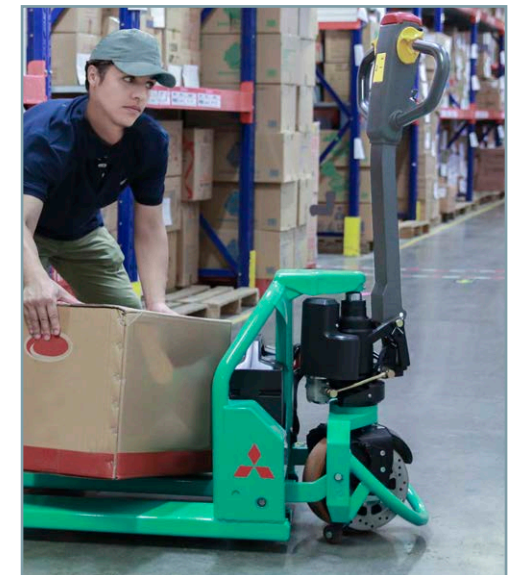

There is more information on PBPL on [mitforklift.com](http://mitforklift.com)



For more extensive information on this range please visit our website [mitforklift.com](http://mitforklift.com)

Continuing improvement may lead to changes in these specifications

[mft2.eu/pbpl](http://mft2.eu/pbpl)

Characteristics		
1.1	Manufacturer (abbreviation)	
1.2	Manufacturer's model designation	
1.3	Power source: (battery, diesel, LP gas, petrol)	
1.4	Operator type: pedestrian, operator standing, operator seated	
1.5	Load capacity	Q kg
1.6	Load center distance	c mm
1.8	Load wheels axle to fork face (forks lowered)	x mm
1.9	Wheelbase	y mm
Weight		
2.1	Truck weight without nominal load	kg
2.2	Axel load with nominal load & maximum battery weight, drive load/side	kg
2.3	Axel load without nominal load & with maximum battery weight, drive load/side	kg
Wheels, Drive Train		
3.1	Wheel type: P=Polyurethane, N=Nylon, R=Rubber	
3.2	Wheel dimension, drive side	∅ mm
3.3	Wheel dimension, load side	∅ mm
3.5	Number of wheels, drive/load side (x=driven)	
Dimensions		
4.4	Lift height	h3 mm
4.9	Height of tiller arm / steering console (min. / max.)	h14 mm
4.15	Fork height fully lowered	h13 mm
4.19	Overall length	l1 mm
4.20	Length to fork face	l2 mm
4.21	Overall width	b1 / b2 mm
4.22	Fork dimensions (thickness, width and length)	s / e / l mm
4.25	Outside width over forks (minimum / maximum)	b5 mm
4.32	Ground clearance at centre of wheelbase (forks lowered)	m2 mm
4.33	Working aisle width (Ast3) with 1000 x 1200 pallets, load crosswise	Ast 3 mm
4.34	Working aisle width (Ast3) with 800 x 1200 pallets, load lengthwise	Ast 3 mm
4.35	Turning circle radius	Wa mm
Performance		
5.1	Travel speed, with / without load	km / h
5.2	Lifting speed, with / without load	mm / s
5.3	Lowering speed, with / without load	
5.8	Maximum gradeability, with / without load	%
Electric motors		
6.1	Rated power of lifting motor (Drive motor capacity [60 min. short duty])	kW
6.2	Rated power of travel motor (Lift motor output at 15% duty factor)	kW
6.4	Battery voltage / capacity	V/Ah
6.5	Battery weight	kg
6.6	Energy consumption according to VDI cycle	
Miscellaneous		
10.7	Sound level at the driver's ear acc. to DIN12053	dB(A)

Mitsubishi PBPL12WPTP 550 X 1000	Mitsubishi PBPL12IPTP 680 X 1000	Mitsubishi PBPL12MPTP 550 X 1150	Mitsubishi PBPL12HPTP 680 X 1150	Mitsubishi PBPL12KPTP 550 X 1220	Mitsubishi PBPL12JPTP 680 X 1220
Battery	Battery	Battery	Battery	Battery	Battery
Pedestrian	Pedestrian	Pedestrian	Pedestrian	Pedestrian	Pedestrian
1200	1200	1200	1200	1200	1200
600	600	600	600	600	600
802	802	952	952	1022	1022
1119	1119	1269	1269	1339	1339
135	140	140	150	144	154
450/885	450 / 890	450 / 890	460 / 890	454 / 890	464 / 890
110/25	115 / 25	110 / 30	120 / 30	110 / 34	120 / 34
P	P	P	P	P	P
250	250	250	250	250	250
80	80	80	80	80	80
1x/4	1x/4	1x/4	1x/4	1x/4	1x/4
110	110	110	110	110	110
635/1200	635 / 1200	635 / 1200	635 / 1200	635 / 1200	635 / 1200
80	80	80	80	80	80
1501	1501	1651	1651	1721	1721
501	501	501	501	501	501
550	680	550	680	550	680
45 / 160 / 1000	45 / 160 / 1000	45 / 160 / 1150	45 / 160 / 1150	45 / 160 / 1220	45 / 160 / 1220
550	680	550	680	550	680
35	35	35	35	35	35
1700	1700	1850	1850	1920	1920
1900	1900	1900	1900	1920	1920
1302	1302	1452	1452	1522	1522
4 / 4.5	4 / 4.5	4 / 4.5	4 / 4.5	4 / 4.5	4 / 4.5
20 / 25	20 / 25	20 / 25	20 / 25	20 / 25	20 / 25
Manual control	Manual control	Manual control	Manual control	Manual control	Manual control
3 / 8	3 / 8	3 / 8	3 / 8	3 / 8	3 / 8
0.8	0.8	0.8	0.8	0.8	0.8
0.6	0.6	0.6	0.6	0.6	0.6
48 / 20	48 / 20	48 / 20	48 / 20	48 / 20	48 / 20
8	8	8	8	8	8
0.15	0.15	0.15	0.15	0.15	0.15
70	70	70	70	70	70

## Mitsubishi PBPL12 Series Electric Hand Pallet Truck

1.2 tonnes



Continuing improvement may lead to changes in these specifications

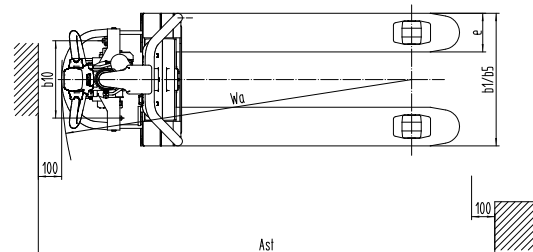
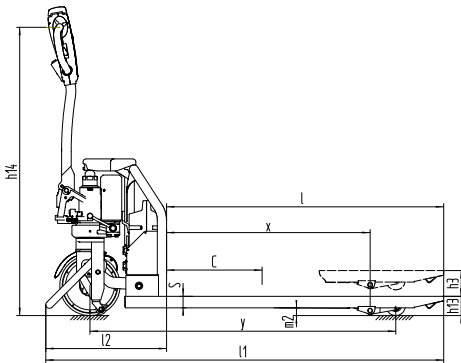

Ast3 = Wa + length of pallet - x + 2\*100



**VDI – PERFORMANCE & DIMENSIONS**  
**1.2 TONNES**



# Mitsubishi PBPL15 Series Electric Hand Pallet Truck

1.5 tonnes



Characteristics		
1.1	Manufacturer (abbreviation)	
1.2	Manufacturer's model designation	
1.3	Power source: (battery, diesel, LP gas, petrol)	
1.4	Operator type: pedestrian, operator standing, operator seated	
1.5	Load capacity	Q kg
1.6	Load center distance	c mm
1.8	Load wheels axle to fork face (forks lowered)	x mm
1.9	Wheelbase	y mm
Weight		
2.1	Truck weight without nominal load	kg
2.2	Axel load with nominal load & maximum battery weight, drive load/side	kg
2.3	Axel load without nominal load & with maximum battery weight, drive load/side	kg
Wheels, Drive Train		
3.1	Wheel type: P=Polyurethane, N=Nylon, R=Rubber	
3.2	Wheel dimension, drive side	∅ mm
3.3	Wheel dimension, load side	∅ mm
3.5	Number of wheels, drive/load side (x=driven)	
Dimensions		
4.4	Lift height	h3 mm
4.9	Height of tiller arm / steering console (min. / max.)	h14 mm
4.15	Fork height fully lowered	h13 mm
4.19	Overall length	l1 mm
4.20	Length to fork face	l2 mm
4.21	Overall width	b1 / b2 mm
4.22	Fork dimensions (thickness, width and length)	s / e / l mm
4.25	Outside width over forks (minimum / maximum)	b5 mm
4.32	Ground clearance at centre of wheelbase (forks lowered)	m2 mm
4.33	Working aisle width (Ast3) with 1000 x 1200 pallets, load crosswise	Ast 3 mm
4.34	Working aisle width (Ast3) with 800 x 1200 pallets, load lengthwise	Ast 3 mm
4.35	Turning circle radius	Wa mm
Performance		
5.1	Travel speed, with / without load	km / h
5.2	Lifting speed, with / without load	mm / s
5.3	Lowering speed, with / without load	
5.8	Maximum gradeability, with / without load	
Electric motors		
6.1	Rated power of lifting motor (Drive motor capacity [60 min. short duty])	
6.2	Rated power of travel motor (Lift motor output at 15% duty factor)	
6.4	Battery voltage / capacity	
6.5	Battery weight	
6.6	Energy consumption according to VDI cycle	
Miscellaneous		
10.7	Sound level at the driver's ear acc. to DIN12053	dB(A)

Mitsubishi PBPL15WPTP 550 X 1000 Battery Pedestrian	Mitsubishi PBPL15iPTP 680 X 1000 Battery Pedestrian	Mitsubishi PBPL15MPTP 550 X 1000 Battery Pedestrian	Mitsubishi PBPL15HPTP 685X1150 Battery Pedestrian	Mitsubishi PBPL15KPTP 550X1220 Battery Pedestrian	Mitsubishi PBPL15JTP 680X1220 Battery Pedestrian	Mitsubishi PBPL15MPSP 550X1150 Battery Pedestrian
1500	1500	1500	1500	1500	1500	1500
600	600	600	600	600	600	600
802	802	952	952	1022	1022	952
1119	1119	1269	1269	1339	1339	1269
140	145	145	155	149	159	142.5
450 / 885	450 / 890	450 / 890	460 / 890	454 / 890	464 / 890	450 / 887.5
110 / 25	115 / 25	110 / 30	120 / 30	110 / 34	120 / 34	110 / 27.5
P	P	P	P	P	P	P
250	250	250	250	250	250	250
80	80	80	80	80	80	80
1x4	1x4	1x4	1x4	1x4	1x4	1x4
110	110	110	110	110	110	110
635 / 1200	635 / 1200	635 / 1200	635 / 1200	635 / 1200	635 / 1200	635 / 1200
80	80	80	80	80	80	80
1501	1501	1651	1651	1721	1721	1651
501	501	501	501	501	501	501
550	680	550	680	550	680	550
45 / 160 / 1000	45 / 160 / 1000	45 / 160 / 1150	45 / 160 / 1150	45 / 160 / 1220	45 / 160 / 1220	45 / 160 / 1150
550	680	550	680	550	680	550
35	35	35	35	35	35	35
1700	1700	1850	1850	1920	1920	1850
1900	1900	1900	1900	1920	1920	1900
1302	1302	1452	1452	1522	1522	1452
4 / 4.5	4 / 4.5	4 / 4.5	4 / 4.5	4 / 4.5	4 / 4.5	4 / 4.5
20 / 25	20 / 25	20 / 25	20 / 25	20 / 25	20 / 25	20 / 25
Manual control	Manual control	Manual control	Manual control	Manual control	Manual control	Manual control
3 / 8	3 / 8	3 / 8	3 / 8	3 / 8	3 / 8	3 / 8
0.8	0.8	0.8	0.8	0.8	0.8	0.8
0.6	0.6	0.6	0.6	0.6	0.6	0.6
48 / 20	48 / 20	48 / 20	48 / 20	48 / 20	48 / 20	48 / 20
8	8	8	8	8	8	8
0.15	0.15	0.15	0.15	0.15	0.15	0.15
70	70	70	70	70	70	70

Continuing improvement may lead to changes in these specifications

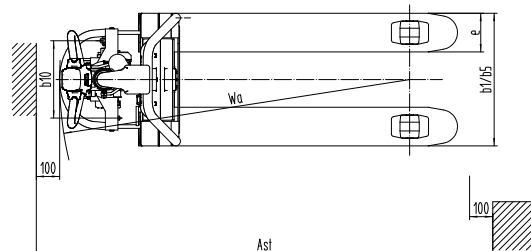
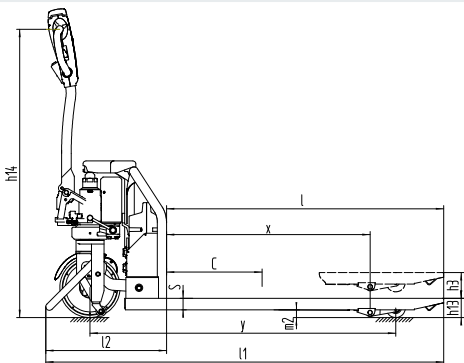

$$Ast3 = Wa + \text{length of pallet} - x + 2 \times 100$$



**VDI – PERFORMANCE & DIMENSIONS**  
**1.5 TONNES**





## Mitsubishi PBPL12-15 Series Electric Hand Pallet Truck

1.2 – 1.5 tonnes

### POPULAR FEATURES

- # 1 Compact design
- # 2 Quick-charging battery
- # 3 High-productivity tiller
- # 4 Maintenance-free battery
- # 5 Easy-entry forks
- # 6 Choice of load capacities
- # 7 Double brake discs (1.5 tonne model)
- # 8 Integrated Rocker Arm (1.5 tonne model)
- # 9 Universal battery exchange

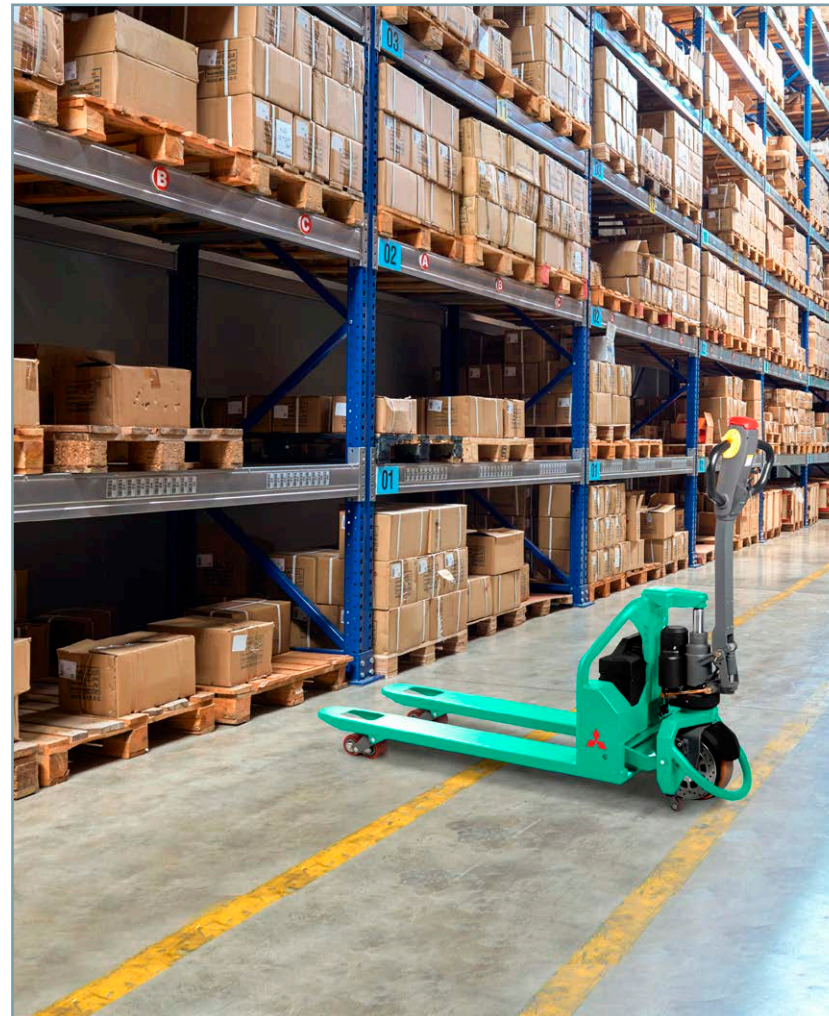

# 1



#2 The PBPL's 48V lithium ion power source charges in just 3.5 hours and offers 6 hours of use.



#3 Multi-function, ergonomic handle with stepless speed control offers high productivity.



#4 PBPL's 48V/20Ah high-capacity Li battery requires no watering and is easy to remove and exchange for fast changeovers.

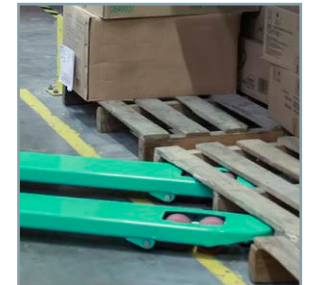

#5 Reinforced fork structure with tapered ends for easy pallet entry



#7 Double brake discs (1.5 tonne model) enhance braking performance.



#9 Batteries can be exchanged easily between 1.2 and 1.5 tonne models for maximum productivity.

Continuing improvement may lead to changes in these specifications

## POPULAR FEATURES

when  
**reliability is  
everything...**



Like any product bearing the Mitsubishi name, our materials handling equipment benefits from the tremendous heritage, huge resources and cutting-edge technology of one of the world's largest corporations – Mitsubishi Heavy Industries Group.



Engineering spacecraft, jet planes, power plants and more, MHI specialises in those technologies where performance, dependability and superiority decide your success or failure...

So when we promise you **quality, reliability and value for money**, you know it's a guarantee we have the power to deliver.

That's why every model in our award-winning and comprehensive range of lift trucks and warehouse equipment is built to a high specification – to ensure it keeps working for you. Day after day. Year after year. Whatever the job. Whatever the conditions.



## **YOU'LL NEVER WORK ALONE**

As your local authorised dealer, we are here to keep your trucks working – through our extensive experience, our technical excellence and our commitment to customer care.

We are your local experts, backed by efficient channels to the entire Mitsubishi Forklift Trucks organisation.

No matter where you are, we are close by – with the capability to meet your needs.



Discover how Mitsubishi gives you more from your local authorised dealer or when you visit our website [www.mitforklift.com](http://www.mitforklift.com)



Performance specifications may vary depending on standard manufacturing tolerances, vehicle condition, types of tyres, floor or surface conditions, applications or operating environment. Trucks may be shown with non-standard options. Specific performance requirements and locally available configurations should be discussed with your distributor of Mitsubishi forklift trucks. Mitsubishi follows a policy of continual product improvement. For this reason, some materials, options and specifications could change without notice.

[mitforklift@mcfe.nl](mailto:mitforklift@mcfe.nl)

WESM1940 (01/19) © 2019 MCFE

MOVE THE WORLD FORWARD **MITSUBISHI  
HEAVY  
INDUSTRIES  
GROUP**

